



**ARCHITECTURAL STREET FURNISHINGS**

[www.asfco.co.uk](http://www.asfco.co.uk) [info@asfco.co.uk](mailto:info@asfco.co.uk) 01484 401414

**STEEL AND  
STAINLESS STEEL  
POST AND RAIL  
SYSTEMS**



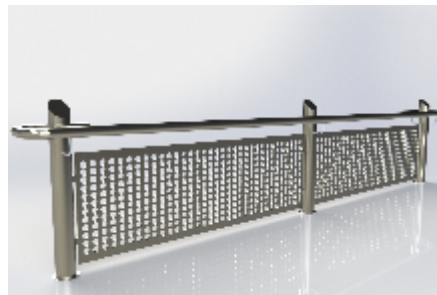

Shown powder coated

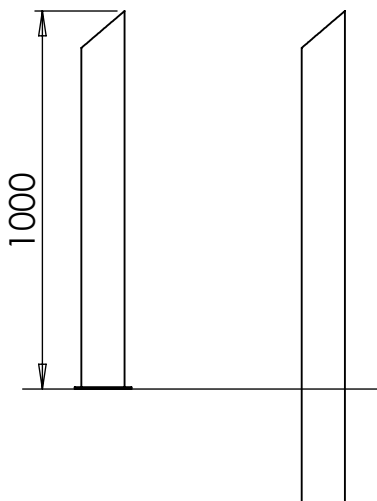

## Post & Rail | ASF 5006 Post - Rail System

### Materials

Standard Finish

Posts are available in all grades of stainless and mild steel.

As standard stainless steel post and rail systems are finished satin brush polished. Other polish finishes are available.

As standard steel post and rail systems are finished galvanised, with polyester powder coating available if required.

### Rail Options

Post and rail systems are usually supplied as single or double rail. Three rail systems and a wide variety of panel designs with and without sight gap are also available. Rails and panels can be straight, curved or cranked to suit gradients.

### Post Options

Posts can be supplied as end posts, intermediate posts or angles to suit any corner. Posts can be manufactured to any height and centres. Partially or fully welded systems can also be supplied.

### Extras

Bespoke adaptations are available. Systems can be manufactured to work with chains, and incorporate step units, gates and other features. Posts can be upgraded with heavy duty inner steel cores to increase impact resistance.

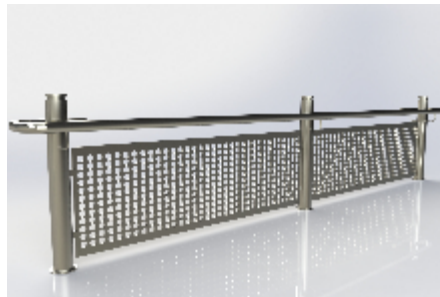

Shown powder coated

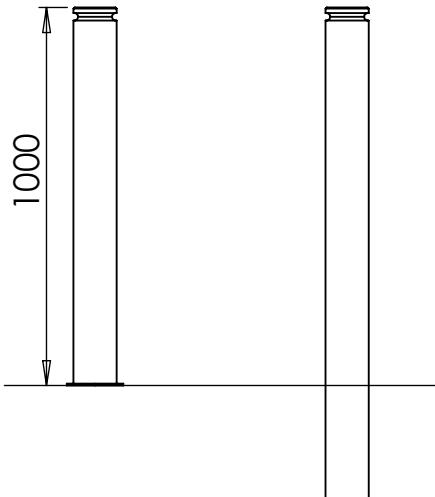

## Post & Rail | ASF 5008 Post - Rail System

### Materials

#### Standard Finish

Posts are available in all grades of stainless and mild steel.

As standard stainless steel post and rail systems are finished satin brush polished. Other polish finishes are available.

As standard steel post and rail systems are finished galvanised, with polyester powder coating available if required.

#### Rail Options

Post and rail systems are usually supplied as single or double rail. Three rail systems and a wide variety of panel designs with and without sight gap are also available. Rails and panels can be straight, curved or cranked to suit gradients.

#### Post Options

Posts can be supplied as end posts, intermediate posts or angles to suit any corner. Posts can be manufactured to any height and centres. Partially or fully welded systems can also be supplied.

#### Extras

Bespoke adaptations are available. Systems can be manufactured to work with chains, and incorporate step units, gates and other features. Posts can be upgraded with heavy duty inner steel cores to increase impact resistance.

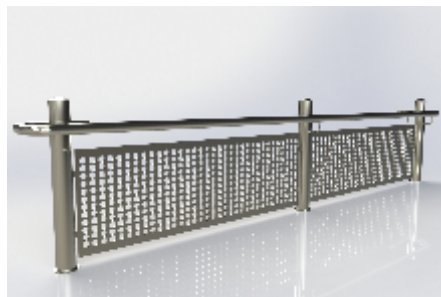

Shown powder coated

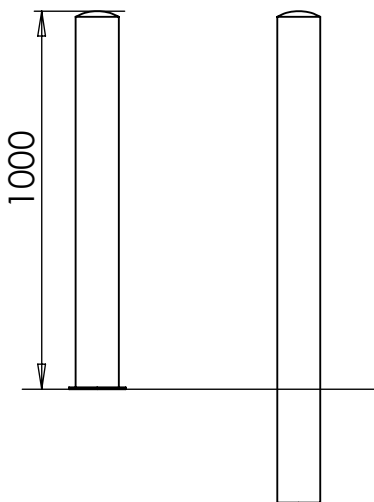

## Post & Rail | ASF 5002 Post - Rail System

### Materials

Standard Finish

Posts are available in all grades of stainless and mild steel.

As standard stainless steel post and rail systems are finished satin brush polished. Other polish finishes are available.

As standard steel post and rail systems are finished galvanised, with polyester powder coating available if required.

### Rail Options

Post and rail systems are usually supplied as single or double rail. Three rail systems and a wide variety of panel designs with and without sight gap are also available. Rails and panels can be straight, curved or cranked to suit gradients.

### Post Options

Posts can be supplied as end posts, intermediate posts or angles to suit any corner. Posts can be manufactured to any height and centres. Partially or fully welded systems can also be supplied.

### Extras

Bespoke adaptations are available. Systems can be manufactured to work with chains, and incorporate step units, gates and other features. Posts can be upgraded with heavy duty inner steel cores to increase impact resistance.

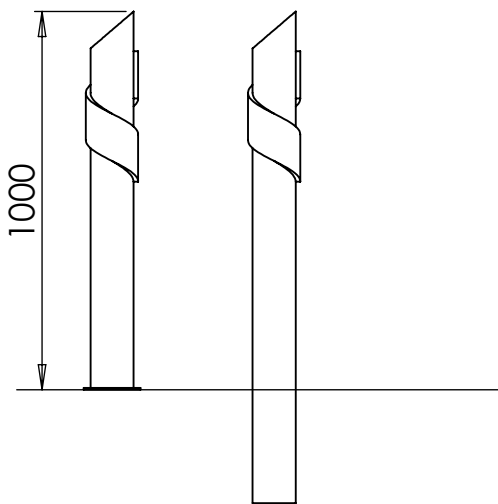

## Post & Rail | ASF 5009 Post - Rail System

### Materials

#### Standard Finish

Posts are available in all grades of stainless and mild steel.

As standard stainless steel post and rail systems are finished satin brush polished. Other polish finishes are available.

As standard steel post and rail systems are finished galvanised, with polyester powder coating available if required.

### Rail Options

Post and rail systems are usually supplied as single or double rail. Three rail systems and a wide variety of panel designs with and without sight gap are also available. Rails and panels can be straight, curved or cranked to suit gradients.

### Post Options

Posts can be supplied as end posts, intermediate posts or angles to suit any corner. Posts can be manufactured to any height and centres. Partially or fully welded systems can also be supplied.

### Extras

Bespoke adaptations are available. Systems can be manufactured to work with chains, and incorporate step units, gates and other features. Posts can be upgraded with heavy duty inner steel cores to increase impact resistance.

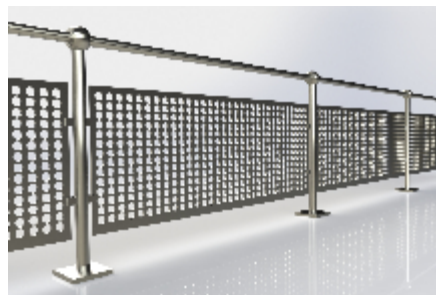

Shown powder coated

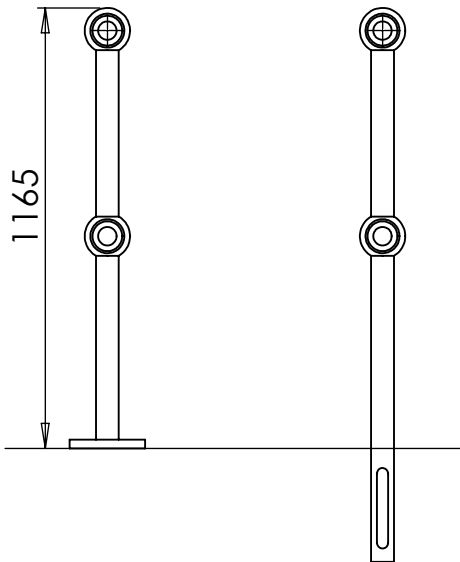

## Post & Rail | ASF Exmouth Post - Rail System

### Materials

Standard Finish

Posts are available in all grades of stainless and mild steel.

As standard stainless steel post and rail systems are finished satin brush polished. Other polish finishes are available.

As standard steel post and rail systems are finished galvanised, with polyester powder coating available if required.

### Rail Options

Post and rail systems are usually supplied as single or double rail. Three rail systems and a wide variety of panel designs with and without sight gap are also available. Rails and panels can be straight, curved or cranked to suit gradients.

### Post Options

Posts can be supplied as end posts, intermediate posts or angles to suit any corner. Posts can be manufactured to any height and centres. Partially or fully welded systems can also be supplied.

### Extras

Bespoke adaptations are available. Systems can be manufactured to work with chains, and incorporate step units, gates and other features. Posts can be upgraded with heavy duty inner steel cores to increase impact resistance.

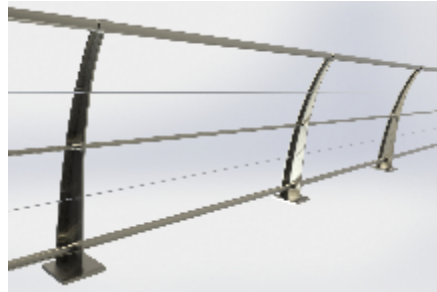
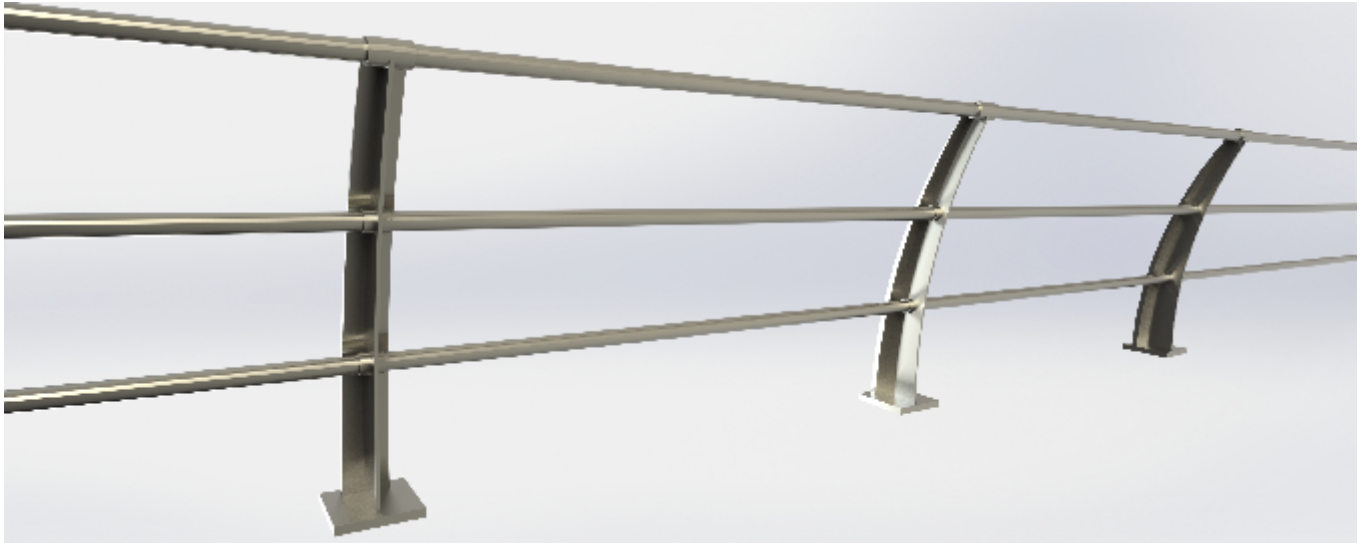

Shown powder coated

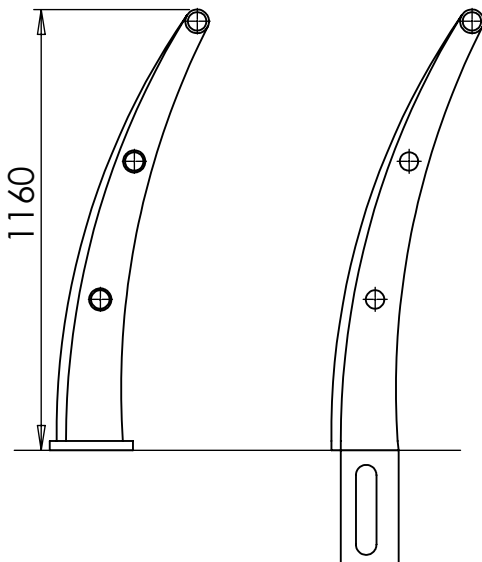

## Post & Rail | ASF Quayside Post - Rail System

### Materials

Standard Finish

Posts are available in all grades of stainless and mild steel.

As standard stainless steel post and rail systems are finished satin brush polished. Other polish finishes are available.

As standard steel post and rail systems are finished galvanised, with polyester powder coating available if required.

### Rail Options

Post and rail systems are usually supplied as single or double rail. Three rail systems and a wide variety of panel designs with and without sight gap are also available. Rails and panels can be straight, curved or cranked to suit gradients.

### Post Options

Posts can be supplied as end posts, intermediate posts or angles to suit any corner. Posts can be manufactured to any height and centres. Partially or fully welded systems can also be supplied.

### Extras

Bespoke adaptations are available. Systems can be manufactured to work with chains, and incorporate step units, gates and other features. Posts can be upgraded with heavy duty inner steel cores to increase impact resistance.